



ARCH NOTES

SEP/OCT 1994

94-5

ISSN 0048-1742

President's Communique	Norma E. Knowlton	3
MCTR News	Roshan D. Jussawalla	4
ADDITIONAL PETER DORNI PIPE DATA		
	Andrew Hinshelwood	5
Letters to the Editor		15
Access to Archaeology: The O.A.S.'s Educational Resource Kits		
	Ellen Blaubergs	22
The 1994 O.A.S. Symposium		28
Isernia - La Pineta		29
From the O.A.S. Office	Charles Garrad	30
Where Does Your Money Go?	Charles Garrad	31
O.A.S. Financial Statements, 1993		32
Editorial	Michael W. Kirby	34

newsletter published by

The Ontario Archaeological Society Inc.

126 Willowdale Avenue, North York, Ontario, M2N 4Y2

ARCH NOTES

Published six times per annum by
THE ONTARIO ARCHAEOLOGICAL SOCIETY
126 Willowdale Avenue, North York
Ontario M2N 4Y2

Canadian Publications Mail Product
Sales Agreement Number 167797
Return Postage Guaranteed

ARCH NOTES

is published with the
assistance of the Ontario Government
through the
Ministry of Culture, Tourism & Recreation

The views expressed in this
publication do not necessarily
represent the views of the
Editor or of
The Ontario Archaeological Society

EDITOR: Michael W. Kirby

P.O. Box 579
Markdale, Ontario
N0C 1H0
Phone or fax: (519) 986-4026

PRESIDENT'S COMMUNIQUE

NORMA E. KNOWLTON

Welcome back after the summer of '94. I hope it has been productive for all the archaeologists out there, as well as pleasant for everyone. As you were informed in the last *Arch Notes*, the OAS was pretty busy in the early part of the summer, but things have slowed down somewhat since then.

The next event is our Symposium 1994, which will be held in Toronto this year. The Registration Form was mailed as an enclosure in the last issue of *Arch Notes*. If you have not yet mailed in your pre-registration by the time you read this, now is the time to do it. You should find a program elsewhere in this issue.

Other events will take place during the Symposium. The Emerson Medal will be awarded this year to an eminently deserving avocational archaeologist. Come and help celebrate. Several Twenty-five Year pins will also be distributed.

Nominations for election to the Board of Directors close at the Annual Business Meeting (ABM). Two persons are required to nominate a candidate, as well as the written consent of the candidate. These should be sent to the Nominating Committee as soon as possible.

Chapters have all received material pertaining to the Strategic Plan. Hopefully the members have been able to discuss this and return some comments before the Symposium so that we can prepare a summary for discussion at the ABM.

Very soon after the Symposium, on November 2, you will have the opportunity to attend a FREE lecture on a major palaeolithic (*Homo Erectus*) site in Italy.

Flyers have already been sent.

As soon as one problem is solved another raises its head. No sooner had we relaxed after the announcement that staff handling archaeological concerns at MCTR would not move out of Toronto, than we find the context of Fort York is being threatened. Although the site itself would not be touched, proposed development very close to the fort would destroy its ambience. More meetings of protest to attend!

A notable event occurred on September 11 when the William E. Taylor Research Gallery was dedicated at the Museum of Civilization in Ottawa. The William E. Taylor Research Award Fund is also being set up, the interest from which will be used to present an annual award for "outstanding achievement in museology". Dr. Taylor is an eminent Canadian archaeologist, who was the Director of the National Museum of Man, and instrumental in developing the Mercury Series as well as the new Museum of Civilization.

Elsewhere in this issue, you will find a short article addressing concerns raised in a recent letter from a member. Perhaps others have as difficult a time as I do reading a financial statement. What do all those numbers mean? I am sure other members also wonder just where their membership fees go. Comments that I have heard from time to time indicate that members believe they are "paying for" items which are, in fact, specifically covered by other sources of revenue. Although this article does not really answer the question as to exactly where all your money goes, it may clear up some misconceptions. This discussion could open up

a whole philosophical debate. Beyond the question of "what am I getting for my money?" are others: "What do I expect

this organization to do (presumably for archaeology)?", and "What is my commitment to the aims of this organization?"

MCTR NEWS

ROSHAN D. JUSSAWALLA

The Archaeology and Heritage Planning Unit has had a busy summer. Several staff members have been hard at work developing a guideline for addressing heritage concerns under the proposed new Planning Act. Meanwhile our marine office has been conducting education workshops for our underwater heritage. Bernice Field has now accepted the position of Licence Officer on a permanent basis. For any questions regarding licences she can be reached at 314-7158. Finally, the licence office is still issuing a few licences for this year. They are as follows:

LIST OF LICENCES ISSUED JULY AND AUGUST 1994

The following list consists of the type of licence, name of licensee, licence number and site location

Consulting:

Ms. Patricia D. Sutherland
Northlands Research
94-105
Province of Ontario

Mr. Ken Swayze
94-113
Province of Ontario

Underwater:

Mr. Ron Beaupre, Ms. Allison Hooper
and Ms. Susan Palmer
94-109
Yankee and J. F. Card and area
of Douglas Point inside Baie Dore

Mr. Kenneth A. Cassavoy
94-101
Atherley Narrows Fishweirs Site
Town of Orillia

Mr. Randy Sullivan
94-107
Whitefish Bay, Lake Superior

Conservation - surface collecting only:

Mr. Andrew J. Stuart
94-104
Northern shore of Lake Superior between
town of Nipigon and Thunder Bay

Mr. Clayton Barker
94-114
Brant County

Mr. Robert von Bitter
94-115
Thorah Township (concession 3, lots 5)

Field School:

Dr. Christopher J. Ellis
University of Western Ontario
Dept. of Anthropology, Social Science
Centre
94-116
The Brian (AfHh-10)
Middlesex County, London

Excavation:

Mr. Charles Garrad
94-112
McQueen-McConnell (BcHb-31) Site

ADDITIONAL PETER DORNI PIPE DATA

ANDREW HINSHELWOOD

Introduction

In *Arch Notes* 94-3, Robert Mayer presented some research notes relating to Peter Dorni tobacco pipes. In his paper, a range of views and data on Peter Dorni pipes collected by Mayer from a variety of sources are laid out in a clear and concise manner.

In my ongoing work with the Whitefish Island (CdIc-2) site collections, I have had the opportunity to review the European clay pipes from the site. The CdIc-2 collection holds numerous varieties of pre- and post-1850 pipe styles, including representatives of the Peter Dorni type, and related variants. While I have recently submitted a paper on the pipes from Whitefish Island to the *Wisconsin Archaeologist*, I felt that it would be useful to present the Whitefish Island Dorni and Dorni-style pipe data, as well as a few personal observations, to *Arch Notes*, to continue the dialogue that Mayer has initiated.

Whitefish Island

Whitefish Island is situated in the St Mary's River, immediately south of Sault Ste Marie, Ontario. The island is recorded as a transitional native fishery centre in early historic records, and these records generally concur that the island was within the territory and control of the Batchewana peoples. This control was further acknowledged in the Robinson treaty of 1850, which included both reserve lands at Batchewana Bay and Whitefish Island as part of the treaty settlement (Canada 1964, 5). Post-1654 fur trade developments in the upper Great Lakes saw the Sault Ste

Marie area as a principal focus of traders seeking connections to the west, with the archaeological consequence that a considerable density and variety of European, and subsequently Euro-Canadian and United States, trade goods are present on surviving sites at the Sault. At Whitefish Island itself, the once-abundant fishery with which it is principally associated attracted the attentions of various 19th century and early 20th century interests in addition to the ongoing native occupations, further complicating the pattern of artifact introduction and deposition.

Who is Peter Dorni?

It is, perhaps, apt that the bowls of Dutch pipes of the mid to late 19th century, including Dorni-style pipes, are plain save for a fine "rouletted" band around the rim (Walker 1977). For, as a close reading of Mayer's paper will allow, arguments concerning the origin and dating of the Dorni pipes are as circular as any roulette wheel, with the solution to the question seemingly as evasive as a successful run of luck at any game of chance. The name Dorni present on a pipe stem has become inextricably linked in the minds of many with a man, Peter Dorni, whom no researcher has demonstrated to have been alive, well and employed as a pipe maker at any time in the past.

We are told firmly by H G Omwake's Dutch informant, G C Helbers, that Pieter Van Doorne, a deft potter present in Holland in 1759, had nothing to do with the Peter Dorni pipes of the subsequent century (Mayer 1994, 10). Omwake also informs us that a certain Peter Dornier shortened his name, perhaps for the sake

of symmetry, and began making pipes around the north of France around 1850 (Mayer 1994, 12). This time, the information is provided without recourse to any source, even the esteemed Helbers. Walker accepts Dorni's account of his own name, placing him in the north of France around 1850 to 1880, again without reference to a primary source (Mayer 1994, 12). While Walker's communication with Forma (see below) regarding the identity of the makers of Sparnaay pipes suggests that he may have had recourse to documents listing pipe makers in the France-Holland region from this time period, in turn of possible relevance to the discussion of Peter Dorni the man, he does not identify these sources. The source of this information may have been a publication cited by E A Wylie (1969, 1), prepared by Helbers and Goedewaagen (1942), which partially reconstructs a pipe makers' list for Gouda using legal records. Hauser and Wilkins (Mayer 1994, 17) also refer to the *circa* 1850 date for Dorni without citing or searching for an original source, all the while lamenting the absence of data on the *terminal* date of Dorni's activities. I myself reiterated this story recently (Hinshelwood, in press) and did not pause to consider the implications until reading Mayer's paper. Perhaps the most glowing report of the unproved Mr Dorni comes from Alexander who states that "his pipes were of the finest quality and earned a good reputation in Europe and America; so much so that they were copied" (Mayer 1994, 17).

The puzzle over the originator of the Dorni pipe is mired in the concurrent problem of multiple imitations of the Dorni style. As with the initial date of Dorni manufacture, the variety, quality and dating of the imitations is not clear. Finding plagiarists of any sort irretrievably

repugnant, Omwake suggests that among the several styles of lettering present on otherwise similar Dorni pipes, the "more clearly formed, slightly larger letters and the more carefully executed decorations" reflect the original product, while the "smaller letters and more slovenly ornamentation" characterise the plagiarized forms (Mayer 1994, 12). Oddly, the sole Dutch researcher whose work has contributed to the discussion seems to be suggesting exactly the opposite. The original Dorni example Don Duco provides for consideration "is a little smaller than a Gouda pipe, and with the kind of clay and finishing it has, is of poorer quality" (Mayer 1994, 19). Depiction of the imitators reaches a height of hyperbole with Rusden's discussion of a New Zealand example. Rusden seems almost overcome with the thought of "unscrupulous" imitators jumping on the Dorni bandwagon and their foul spawn "creeping onto the market" (Mayer 1994, 19). In this frame of mind, it is hardly surprising that the improbability of Dutch pipe makers producing pipes from different molds for New Zealand than for the United States, especially in the light of their relative size as markets, is overlooked. It is more probably the United States McKinley Tariff Act of 1891, the dating device noted earlier in Mayer's paper (Mayer 1994, 14), than some urge to be caught in their crime that caused the Dutch manufacturers of Dorni-style pipes to add *Gouda Holland* to the reverse side of their *Peter Dorni* marks.

Whitefish Island Dorni and Dorni-style pipe stems

Decorated English and European pipe stems in the Whitefish Island collection may be grouped into four descriptive categories. The first are the box and dot motifs (Figure 1b-f), a style of stem that is

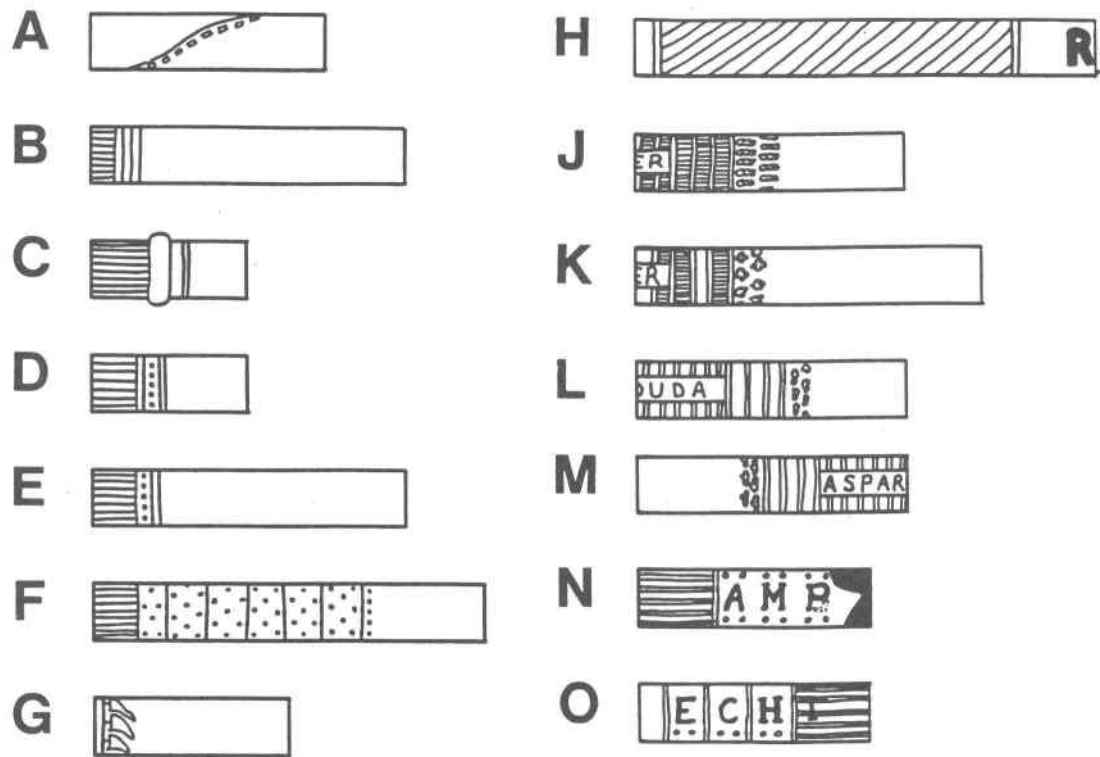

Figure 1. Decorated Stems Cdlc-2

thought to be primarily English (Hansen 1971). The second category of decorated English pipe stems are the *Ring/Bristol* "barber pole" motif stems (Figure 1h). The raised encircling bar and raised encircling leaf motif stems, including all of the Dorni and Dorni-style stems in the collection (Figure 1j-m) form a third category. The Dorni-style stems are generally considered as Dutch products, although, and the manufacture in Germany (Gifford 1940, 125: cited in Mayer 1994, 16), and in Scotland (Sudbury, 1980: cited in Mayer 1994, 17) after 1870 is recognized. While Figure 1n/o shows a decorative motif reminiscent of the box and dot forms, this stem has been grouped with the Dorni-style stems on the basis of its presumed Dutch manufacture. The final category includes the miscellaneous decorated stems of the collection, including the spiral impressed stem (Figure 1a), discussed below.

Peter/Dorni. The two stems bear parts of a *Peter/Dorni* mark. Both show slightly different decorative treatment. The basic motif includes open panels on either side of the stem, with *Peter* and *Dorni* appearing on opposite sides in raised serif capitals within. The panels are framed above and below by a series of raised bars running across the stem. At both ends of the panels are four raised encircling bars followed by two encircling rows of raised leaves. Decorative treatment varies with one stem showing hatching between the four raised encircling bars at either end of the panels (Figure 1j) with the other showing the hatching alternating with smooth sections (Figure 1k).

If Omwake's definition of the 'true' Dorni (Mayer 1994, 12), which includes the presentation of the name in raised block (sans serif) letters, rather than the serif

letters noted here, then the Whitefish stems are not original Dorni. Whether this assumption holds or not, future research will determine. In the meantime, the style of lettering appears to be a potentially useful observation to record. A *Peter/Dorni* recovered at Ermatinger House, in close proximity to Whitefish Island, is illustrated in Reid (1977, 61: Fig. 37). This stem bears alternating hatching between raised encircling ribs and block lettering. The stem fragment recovered by Kenyon near Binbrook, Ontario and illustrated in Mayer's paper (Figure 2c) shows alternate hatching and raised serif lettering. In a similar fashion, both the *Peter/Dorni* and *Mullenba/-ewald.Hohr* stems illustrated in Gifford's report on Fort Ticonderoga and illustrated in Mayer (1994, 15) are also similar to the second Dorni stem illustrated. A stem with identical decoration, but marked *J & G PRINCE/IN GOUDA* is illustrated in Walker (1971, 34). Bradley adds to the complications inherent in the imitations of the Dorni-style, noting that the Dorni-style pipe recovered from the *Farewell* shipwreck bore a registered mark of *J & G Prince* on the bowl, with the *Peter/Dorni* mark on the stem, a combination which he suggests as proof that the pipe was a German imitation (Mayer 1994, 16). A complete Dorni pipe of the second style described above is illustrated in a page from an 1875 Wm DeMuth and Co catalogue reproduced (poorly) in Sudbury and Pfeiffer (1983, 72), and (clearly) in Sudbury (1986, viii). This complete pipe shows the roulette line, but not the bowl finish. It is interesting to note that DeMuth & Co was an importer of pipes in New York City, not a manufacturer, allowing the illustrated pipes to have come from any number of foreign and domestic sources (Sudbury and Pfeiffer 1983, 73). It

is of further interest that the *Glasgow*/"Home Rule" pipe illustrated next to the Dorni pipe also shows an apparent roulette bowl finish.

A Sparnaay/Gouda. One stem fragment from Whitefish Island bears a clear *A Sparnaay/Gouda* mark (Figure 1l and 1m). A smaller fragment shows a similar design and the raised serif letters *Gou-* within an open panel. The decoration on both stems is identical to the second *Peter/Dorni* (alternating hatching) discussed above.

Walker notes that a number of late 19th century Dutch makers produced pipes under variations of the name A. Sparnaay. In turn, the style of the pipes places them within the large trade in imitation Dorni pipes (1977, 683: n.81). Sparnaay pipes have been recovered from Longlac Post (Dawson 1969, 46) and Michipicoten Post (Forma 1971, 50) in northern Ontario, the latter being similar in decoration to the second Dorni (alternating hatching). Again, the similarities between the Dorni, Sparnaay and Prince stems, the latter illustrated by Walker (1971, 34), are noted.

One well-worn stem fragment from CdIc-2 bears a complex decorative motif combined with the letters *-echt* on one side and *-amp*, *-amf* or possibly *-amb* on the other (Figure 1n and 1o). The stem decoration is based on a series of raised horizontal lines overlain by both raised encircling bars and patterns of dots. It is tempting to complete the maker's name as Gambier, a well known French pipe manufacturer, but the name on the obverse is almost certainly Utrecht, a Dutch city. Walker records a Gambier factory in Givet and Paris (1971, 30: 1977, 292), but makes no mention of Utrecht. Duco (1986), in an overview of Gambier marks, shows no marks resembling this stem. It is possible

to assume, therefore, that this stem represents yet another imitation of an unidentified but popular style, or the application of a well known maker's name on a pipe manufactured by a less well known maker.

A single stem fragment, shown in Figure 1a, bears an unusual design produced with an impression similar to the roulette line of the bowls described below. A design in the form of a line of small, regular rectangles is impressed in a spiral fashion around the stem. While the impressions are similar to those found on one of the rim fragments, there is no proof that rim and stem are from the same pipe or manufacturer.

Plain (Dutch?) bowls from Whitefish Island

Roulette impressions at the rim and stroke burnishing of clay pipe bowls is typical of early English pipes (Hamilton and Lunn 1984, 2; Wylie 1969; Walker 1977, 1408; 1446; 1448), and of Dutch pipes of all periods (Hamilton and Lunn 1984, 4). The presence of stroke burnished bowls in association with Dorni-style stems is therefore an association which may be useful in future research into the Dorni-style pipe. The appearance of stroke burnishing is clearly illustrated on a bowl fragment from a site in the Canadian High Arctic by Ritchie (1978, 126: Fig. 3). At Whitefish Island four fragments representing at least three pipes show a roulette impression immediately below the rim. The CdIc-2 pipes are probably Dutch and contemporary with the Dorni and Dorni-style stems and possibly the spiral roulette impressed stem.

Mayer's illustrations of the Dorni pipe recovered from the *Farewell* shipwreck by Hugh Wyatt (Mayer 1994, 12-13) led me to reexamine one complete (reconstructed) plain bowl and one plain bowl from the

Whitefish Island collection. Prior to seeing Wyatt's pipe, I had focused principally on the impressed circles, 0.50 cm diameter, with an abstract design in relief found on the backs of the bowls, that I took to be maker's marks. These marks (Figure 2) have not been interpreted, and I did not see any like them in the literature I reviewed. However, in looking again at the bowls with the thought that they may be related to the Dorni-style stems from the collection I see that they bear the faint vertical marks typical of stroke burnishing and that there is a slight, intermittent impressed line around the top of the more complete bowl.

In light of the relatively distinctive finishing of Dutch pipe bowls by stroke burnishing and occasionally by roulette impressions, it would seem important to note this in the analysis of complete pipes and bowl fragments. Dorni-style pipes which lacked stroke burnished finish on the bowls could indicate a different region or date of manufacture, as highlighted by Bradley (cited in Mayer 1994, 14). It would also serve as a more objective means of identifying "good" and "poor" quality, a judgment often used in sorting Dorni-style pipes. It is also important to allow stroke burnishing to take precedence as an analytical variable over roulette impressions in light of the apparent application of a roulette band to a Glasgow pipe, as noted above (Sudbury and Pfeiffer, 1983, 73). It is unfortunate in this case that Bradley was not able to analyse the specimen recovered by Wyatt. Unlike Dorni-style stems, there appears to be at least a few instances in which stroke burnished bowls are dated to reasonably short time periods. A stroke-burnished bowl fragment was recovered from an 1830-1840 deposit at the Marina site (Salzer and Birmingham 1981, 139; fig. 39d). Salzer

and Birmingham also note the presence of stroke-burnished bowl fragment from Old Sacramento, dating to 1852 (Humphrey 1969, 20).

Dating Dorni-style pipes

Dating the Dorni-style pipe must proceed from solid data. Presently, such data appear to be lacking for the initial date of Dorni-style manufacture, although some clear temporal landmarks are available within the range of manufacture. The addition of country of origin information on the stem separates post-McKinley Tariff Act pipes from earlier examples. Sudbury (1980, 36) has indicated that his own research has placed the earliest *McDougall/Glasgow* Dorni-style pipes at about 1870 (see list reproduced in Mayer 1994, 18), and other lists may surface over time to provide initial dates of other Dorni pipes. The initial date of Dorni manufacture in France or Holland will in turn require the attentions of researchers in those countries. Stroke-burnished bowls have been found in well dated archaeological context at the Marina site and Old Sacramento, and it may only be a matter of time before Dorni-style stems are also reported from well-dated contexts and in association with stroke-burnished bowls.

Future directions

Continuing research into the nature of the "Dorni-style" pipe in North America may benefit from the relaxation of the requirements for inclusion within this class of artifacts. Certainly, there may yet be some dusty tome or family history of the Dorni clan awaiting discovery in the north of France or Holland, which only the consistent ferreting of a researcher like the late Walker or Robin H Smith might recover. In the meantime, I would like to suggest that the origin of the Dorni-style pipe be set aside, along with the discussion

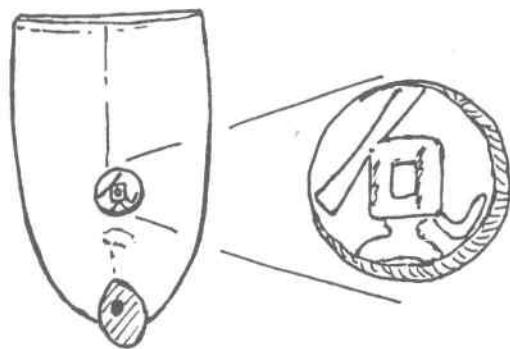

Figure 2. Stroke burnished bowl with impressed mark, Cdlc-2

of the identity of Dorni himself, and that all of the pipes bearing stems decorated with encircling rows of raised encircling bars and/or raised leaves, with or without hatching between the bars and with or without panels bearing a maker's name be included for consideration. In this way, the range of artifacts under consideration will be greatly increased to include the 'true' and 'imitation' Dorni pipes, as well as the true and imitation Prince, Sparnaay, Gambier and other French, Dutch and German pipes of similar design. In this latter regard, I note the personal communication of Iain Walker to Gary Forma in which he notes that "there was no Sparnaay with the initial A known at present to have been manufacturing pipes in Holland" (1971, 50), which in turn suggests that imitation of the Sparnaay type was also occurring. By expanding the discussion beyond the limits of the undefined 'true' Dorni pipes, we may recover data on distribution (and perhaps more specimens from datable contexts), motif variation and patterns of trade that could ultimately lead to a solid base for the resolution of the Dorni dilemma.

Mayer's excellent paper summarizing published and unpublished data on the distribution and form of Peter Dorni pipes in northeastern North America provides a very useful starting point for identifying and addressing several important questions about Dorni-style pipes. Within his paper as well, there are indications that many of the research directions taken previously have led to the development of fairly circular arguments about what constitutes a 'true' or 'imitation' Dorni pipe. I feel that the importance of the origins of the Peter Dorni are less pressing than the need to develop consistent formats for reporting on the distribution, dating and decorative variations within the overall Dorni-style pipe industry. A series of research questions is presented below, in no particular order, which may help to focus the research into the Dorni-style pipe.

- what documentary evidence is there for Peter Dorni, pipe maker, and what dates for Dorni may be derived from these records?
- what range of motifs is present on Dorni-style pipe stems?

- what manufacturers made Dorni-style pipes, and during what periods?
- what motifs are associated with specific manufacturers or dates?
- what is the distribution of Dorni-style pipes in archaeological context?
- How well are the archaeological specimens dated?
- What range of bowl forms and styles are associated with manufactured Dorni-style pipes, and is the stroke burnished bowl the only associated form?
- Is there an actual relationship between the quality of Dorni-style pipes and the age or place of manufacture of the pipes?
- How does the quality of the pipe relate to the concept of a 'true' Dorni pipe?

Conclusion

The Peter Dorni pipe stem is one of the more popular among archaeologists because of its remarkable rococo stem. Encountering a highly-decorated stem is a pleasure when hundreds of plain-stem fragments are being washed and catalogued, when it has been a long day walking otherwise sterile fields or when it is necessary to make some passably interesting comment about an otherwise unremarkable site in a report. The wide range of motifs and makers of Dorni-style pipes suggests that they were equally well received during their period of manufacture and sale. The fact that they are pretty artifacts, and readily identified, does not in turn mean that they are useful index fossils for site dating or interpretation. Insecure dating of the style, dispute over the 'true' Dorni decorative motif and the range of later variants, the number of

manufacturers producing these pipes, and limited reports of pipes from tightly-dated archaeological contexts has restricted overall understanding of style. It has been argued in this paper that debate over the origin and imitation of Dorni-style pipes has distracted researchers from addressing more basic questions. The class of Dorni-style pipes should be expanded to include all of the Dutch, German, French, Scottish and other pipes of the mid- to late-19th and early 20th centuries which bear variations of the basic motif. Then a series of simple, direct questions regarding the style may be addressed without the distractions of earlier discussions. The discussions concerning the origin and dating of the Peter Dorni pipe have many parallels in the discussions concerning the TD pipe and variants (Walker 1966). In this case, the failure to identify a historical pipe maker "T.D." to the satisfaction of all researchers has not interfered with the determination of datable variants within the overall range of T.D. pipe styles. It is hoped that the discussion initiated by Mayer will ultimately bear similar fruits.

References

Note: references cited in the text have largely been taken from the excerpts presented by Mayer (1994). Rather than reproduce his bibliography here, I refer readers to that paper for bibliographic details.

Canada (Government of Canada)

- 1964 "Copy of the Robinson Treaty Made in the Year 1850 with the Ojibewa Indians of Lake Huron Conveying Certain Lands to the Crown" reprint, Queen's Printer and Controller of Stationery, Ottawa.

Dawson, K C A

- 1969 "Archaeological Investigations at the site of the Longlac Historic Trading Post, Thunder Bay District, Ontario." *Ontario Archaeology* No. 12.

Duco, D

- 1986 "Pipemarks from the Gambier Factory" in *Historic Clay Tobacco Pipe Studies, Volume 3*, B Sudbury (ed). Ponca City, Oklahoma.

Forma, G

- 1971 "Michipicoten Archaeology 1971: Investigations at the Hudson's Bay Company Fur Trade Post." Ontario Department of Lands and Forests, Parks & Recreation Areas. Manuscript on file, Ministry of Culture and Communications Field Services Branch, Thunder Bay.

Hamilton, F A and K Lunn

- 1984 "Three Centuries of Clay Tobacco Pipes from London, England." *Research Bulletin No. 227*, Parks Canada, Ottawa.

Hanson, Lee H, Jr

- 1971 "Pipes from Rome, New York." *Historical Archaeology* V, pp 92-99.

Helbers, G C and D A Goedewaagen

- 1942 *Goudsche Pijpen*. N V Uitgevers-Mij Atlantic, Amsterdam (cited in Wylie, 1969).

Hinshelwood, A

- in press "Descriptive Analysis of 19th Century European Clay Pipes from the Whitefish Island Site (CdIc-2), Sault Ste Marie, Ontario." *Wisconsin Archaeologist*.

Mayer, R G

- 1994 "Some Research Notes on Peter Dorni Tobacco Pipes in Ontario." *Arch Notes* 94-3:10-22.

Reid, C S Paddy

- 1977 "Mansion in the Wilderness: the Archaeology of the Ermatinger House." *Research Report 10*, Ministry of Culture and Recreation, Historical Planning and Research Branch, Toronto.

Ritchie, C

- 1978 "Nineteenth-Century Clay Tobacco Pipes from the High Arctic." *Canadian Journal of Archaeology* 2:123-137.

Salzer, R and R Birmingham

- 1981 "Archaeological Salvage Excavations at the Marina Site (47 As 24) Madeline Island, Wisconsin." Manuscript report submitted to Interagency Archaeological Services, National Park Service. Contract No. C3543(75).

Sudbury, B

- 1986 "Preface." in *Historic Clay Tobacco Pipe Studies, Volume 3*, B Sudbury (ed), Ponca City, Oklahoma.

Sudbury, B and M A Pfeiffer

- 1983 "Clay Pipes in an 1875 Wm DeMuth & Co Catalogue." in *Historic Clay Tobacco Pipe Studies, Volume 2*, B Sudbury (ed), Ponca City, Oklahoma.

Walker, I C

- 1966 "TD Pipes: A Preliminary Study." *Quarterly Bulletin of the Archaeological Society of Virginia* 20(4):86-102. 1969
- 1971 "Nineteenth Century Clay Tobacco Pipes in Canada." *Ontario Archaeology* 16:19-35.
- 1977 "Clay Tobacco Pipes, with particular reference to the Bristol Industry." *History and Archaeology* 11 (a-d), National Historic Parks and Sites Branch, Parks Canada, Department of Indian and Northern Affairs, Ottawa. Wylie, E A
- Research on Clay Pipes. Paper presented at the Second Annual Meeting of the Canadian Archaeological Association, Toronto. Manuscript on file with the National Historic Sites Service.

MUSÆ MUSEÆ

Archaeologists find out the most about ancient people from the stuff they left lying around. Busted utensils, chewed bones, etc. Richmal Compton's William complained about the stupidity of the Romans: "They just went around smashin' pots and throwin' money away". And he had a good point; you see, Man's basic untidiness is all that archaeologists are able to document—all that disgusting busines of prodding around in Grey Owl's privy, for example (which they did a few years ago, by the way) and finding his Aspirin bottles. If he hadn't needed to use a privy, presto! no Aspirin bottles, or any other muck either.

The point is, there are doubtless many races, tribes, breeds and even whole species of ancient Man about whom we know absolutely nothing because, unlike the slobs who became the dominant *Homo sapiens*, they took the trouble to keep things neat and tidy. No burnt sticks littering their caves, no smashed bone scrapers, no half-consumed haunches of venison. "Ug! Be a good sub-boy and tidy your corner of the cave." No, it's thanks to this breed of anal retentives of the far distant past that *Homo invisibilis* left nothing behind. He disappeared into the damp, writhing mists of prehistory as completely as this cliché ought to have done.

And as I will too...

Fecit from the IICCG newsletter Bulletin June 1994

CENTRAL LIBRARY HAS COLLECTION ON ABORIGINALS

The North York Public Library has a native people's collection of more than 2,000 items on land rights, self-government, government programs, medicine, religion, the arts and more. Video and audio tapes are included in the collection, located on Level 3 at the North York Central Library. For more information call 395-5666.



LETTERS TO THE EDITOR

Dear Mike,

It is with understandable interest that I comment on the first *Ontario Archaeology* to appear under Alex von Gernet's editorship. Both in terms of the attractive format and the quality of the contents, *OA* 57 sets a high standard for future issues, contributors and editors. Von Gernet's editorial essay in particular should be read and digested by all who are concerned about archaeology's rôle at the *fin de siècle*. Von Gernet reminds us that what we commit to writing no longer entertains a few *cognoscenti* before vanishing into the depths of a university library; rather it has a potential impact on the lives of our fellow citizens. His recommendation that we use care in handling our evidence, especially documentary evidence, should be taken to heart.

Since he advocates that our discipline foster internal diversity, von Gernet will forgive me if I dispute one or two of his contentions. My review of Pendergast's *The Massawomeck* cannot be viewed as less "pertinent" than Fitzgerald's "since it is based primarily on an evaluation of ...ideology." If "...theories of knowledge are as much a part of archaeological research as are field...procedures" then scholars are as much responsible for their "ideologies" as they are for their data and it is as "pertinent" in a review to discuss the former as the latter. That I showed myself "more interested in generalizations about human behaviour than in the

particulars of native history and prehistory..." is not a mere "ingrained ism" of mine, but part of the "theory of knowledge" to which I subscribe, that is, that the particulars of archaeology and history are less important than the generalizations for which the particulars provide evidence. In this I am in good company, as a glance at the literature coming out of the USA and elsewhere will show. It is quite true that "...many Ontario researchers never did quite get the hang of..." "...an epistemology...fashionable in American graduate schools in the 1960s and 1970s." This is not the cause for satisfaction that von Gernet imagines it to be. It means that Ontario archaeology continues in its intellectual isolation from the rest of the world. Under such a condition can we then fulfil the mandate which von Gernet rightly advocates in his thoughtful and thought-provoking article?

Ontario Archaeology's editor has done invaluable service by putting together a *Guide for Standardized Manuscript Production*. I earnestly conjure all prospective contributors, be they eager undergraduates or jaded professors emeriti, to read and follow von Gernet's instructions. It will not only sustain the standards of the journal, but also make the editor's difficult job significantly easier. Towards this laudable goal I also heartily endorse the statement in the current *Arch Notes* (94-4:35): "In fairness to authors, manuscript reviewers should return their assessments promptly". Fellow archaeologists, an

editorial request to review an MS is not an unwarranted intrusion into your scholarly life. It is an accolade from your peers, a recognition that you are part of a community of scholars that values your judgment. Please respond to these requests with the promptness and care which they merit. Only thus will *OA* continue to be what it is now and has been in the past, a great archaeological journal.

Sincerely yours,
Dr Peter Reid
University of Windsor
Dept. of Sociology and Anthropology

Dear Editor,

With or without our help, the metaphysical wheel has rolled round a few more degrees since the publication of Dr Alex von Gernet's thoughtful and thought-provoking essay in the recent *Ontario Archaeology* (von Gernet 1994). In that time I have had time to chew those knuckles a little more, especially in the light of some of his observations on '...Metacarpals' (Adams 1994). It came as a bit of a surprise to find out that I had a *Weltanschauung*, but I am beginning to realize that in this expanding universe one must always expect the unexpected.

Since he asked (albeit rhetorically), I have been trying to assess what exactly I do make of the article by Fox and Molto on the Shaman burial of Long Point (see von Gernet 1994:7). As one would expect of an article by researchers of their calibre, the data and interpretations laid out by Fox and Molto (1994) are impressive and stimulating. I am not equipped to comment on the physical anthropology so I will restrict my comments to Fox's interpretations. Following descriptions of the artifacts found accompanying the burial, Fox uses archaeological and ethnographic

evidence from a wide variety of sources against which to evaluate the findings from the Long Point Burial. He lays out his data in the following manner:

a) marten/otter skulls have been found in numerous archaeological mortuary contexts and these have been interpreted by archaeologists as the physical remains of medicine bags, similar, if not identical to, those used by contemporary medicine men.

b) bear teeth, face and jaw bones have been found in association with human burials from Archaic, Woodland, Proto-Historic and Historic sites throughout the Great Lakes region.

c) bear and otter are historically known to be strong medicine animals among the Iroquoians and Algonkians (as well as further afield); thus the presence of bear facial elements can be interpreted as evidence of shamanistic practices, either as masks or as a source of 'bone dust'.

d) the other artifacts found with the burial (stones, 'whetstone', bone tube) are consistent with and similar to the kinds of objects contained within contemporary medicine bags.

The assumption one is left to draw, even though it is not explicitly stated, is that historically-documented shamanistic practices have remained essentially unchanged over the last three thousand years.

So far so good. Up to this point the interpretations, implied and explicit, are well supported by the evidence presented. Fox's assumption that the material remains represent evidence of shamanism is neither more bold, nor inherently more conjectural, than suggesting that someone buried in a wooden box with a gilt crucifix and a string of rosary beads was probably a Christian. We have been asked to

'buy' Fox's extrapolation of a set of historically-documented practices into the distant past, but he has given us good reason to accept his deal.

Using the isolated location of the burial away from the village as supporting evidence, Fox then concludes that the remains at Long Point are those of a shaman, that he was a special member of his band and that his passing may have been greatly mourned. Up to this point, we have been on a fairly secure footing. Interpretations have been largely based on physical evidence, or reasonable extrapolations therefrom. These final statements, while they may well be true, are neither possible to demonstrate nor necessarily valid conclusions to reach from the evidence. They do, however, raise some interesting points.

If we refer back to the numerous archaeological examples cited in the article, we find that burials with bear, otter and marten bits, interpreted here as shamanistic articles, are frequently found in multiple burial mounds or in cemeteries. Indeed, some of the most lavish burials, such as Burials 1, 2, 6 and 7 at Serpent Mounds (Johnston 1968) and Burial 15 at the Hind Site (Ellis, Kenyon and Spence 1990:117) complete with bear masks, bear jaws and modified small carnivore mandibles, have been found in multiple burial sites. The only factors which would seem to distinguish the Long Point burial from those cited are its isolated location and its age. Should we, therefore, interpret all burials with these items as those of shamans, or only as evidence of shamanistic practice? Should only isolated burials with the requisite grave goods be interpreted as shamans' burials? Or can only isolated Middle/Late Woodland transition period burials of this nature be considered in this

light? Can we archaeologically distinguish between those whose world view is shaped by shamanism from those who practice shamanistic arts? Can we even legitimately assume that the things which accompany us to the grave provide some indication of our status, societal function or beliefs? Can we attach too much significance to the location of a burial? Clearly, it is possible to come up with plenty of questions for which we have only limited or partial answers.

The reasons for burying someone away from everyone else are legion. The individual in question may have been an outcast, despised, rejected, perhaps feared. He may have been visiting from another community or simply travelling through. Or, who knows, he may simply have liked to sit and cogitate on the infinite mysteries of the universe under a particularly large and shady oak tree¹ at the lake shore; so fond, in fact that his family decided that it would be fitting to bury him where his spirit could continue its meditations.

It is possible that Bill Fox is right and that the person whose remains were buried at Long point was a shaman. He hasn't had to climb too far up the cone² from Certain Knowledge to reach that conclusion. I probably even believe him. But if he had argued that this man did practise soul flight, or was a medicine man who transformed into a bear, I would have to assume that he was getting his information from beyond what the archaeological remains can provide.

As Dr von Gernet has indicated, to a certain extent 'generalizations observable in the present may be persuasively related to an unobservable past' (1994:7). While I believe that generalizations about ideology are inherently more conjectural than

other forms of archaeological reconstruction (indeed I most definitely do), it does not mean that we should not try, that such attempts are not valuable, and it does not mean that we should be any the less rigorous in our approach. However, we also need to recognize that human experience and human perceptions are as varied as we are numerous. We may share basic ideologies, sets of values, even symbols, but the ways in which we understand and interpret them is personal and unique. Ask a Pentecostal about Christianity—you would be hard pressed to accept that they were talking about the same religion, although they share the physical symbols and the mythological characters. Are we to assume that such variety of interpretation and understanding did not exist during the last 3,000 years? Frankly, I find that hard to accept. Such varieties need to be considered before we get too enthusiastic about describing the way in which people(s) thought and believed in the past. In the title and abstract of 'The Shaman of Long Point' we are left in no doubt that the authors believe that the burial at Long Point was that of a shaman. Fortunately, in the body of the report, their interpretation is less dogmatic. Such statements as "What remains are suggestive of magic and curing" and "...his possessions and isolated grave suggest that he was a special member of his band." are interpretive. They are possibilities, perhaps even probabilities, not certainties. The authors have provided us with the wherewithal to come to our own conclusions—to agree or disagree as we see fit. And that is how it should be.

Nick Adams

Adams Heritage Consultants
3 Main Street, P O Box 150
Newboro, Ontario, K0G 1P0

Notes

1. Obviously a predecessor of the one that blew down exposing the burial!
2. I was unaware that I was plagiarizing Christopher Hawkes. I thought I was adapting E F Schmachers' *Levels of Being*, which he, in turn got from...well, you get the picture.

References

- Adams, N
1994 Gnawing Gently on the Metacarpals. *Arch Notes* 94(1):9-15.
- Ellis, C J, I T Kenyon and M W Spence
1990 The Archaic, IN *The Archaeology of Southern Ontario to A D 1650*. Occasional Publication No 5 of the OAS London Chapter, London.
- Fox, W A and J E Molto
1994 The Shaman of Long Point. *Ontario Archaeology* 57:23-44.
- Johnston, R B
1968 The Archaeology of the Serpent Mound Site. *Royal Ontario Museum Art and Archaeology Occasional Paper 10*, Toronto.
- von Gernet, A
1994 Archaeology as Discourse: An Editorial Essay. *Ontario Archaeology* 57:3-22.

Dear Editor:

I would like to correct, if I may, a slight error concerning the presence of little barley (*Hordeum pusillum*) in Ontario, as reported in the recent article "The Olmstead Site, A Middle Iroquoian Village in

the City of Hamilton" published in *Arch Notes* 94-4, Jul-Aug 1994, pp 11-34.

The authors state that little barley "has not been found elsewhere in Ontario" (p 30). This particular species has been recovered previously from two prehistoric Neutral Ontario sites. Two seeds were found in the middens of Harrietsville Village (AfHf-10), Middlesex County, and reported in 1986 (Ounjian 1986). (Incidentally, these two seeds now have the particular distinction of sitting encrusted in gold in the Smithsonian where they were sent for examination using scanning electron microscopy!)

The second instance of little barley comes from the Pincombe 5 site (AfHh-71), also in Middlesex County, and consists of 8 seeds recovered from one midden (Ounjian, in progress). There may be more instances of little barley in Ontario sites that I am not aware of; I invite further information on this subject.

It is interesting to note that historically both the Chippewa (Densmore 1928) and the Potawatomi (Smith 1933) used the root of little barley for medicine, indicating another possible use for this plant besides subsistence.

Yours sincerely,
Glenna L Ounjian
16 Larchwood Place
Brampton, Ontario, L6S 5V3

References Cited

Densmore, Frances

- 1928 *Uses of Plants by the Chippewa Indians*. Smithsonian Institution: Bureau of American Ethnology Annual Report No 44:273-379.

Ounjian, Glenna L

- 1986 Subsistence Patterns of the Ontario Indian: The Paleoethnobotany of the Glen Meyer-Neutral: A Preliminary Report. Report to the Ontario Heritage Foundation, Ministry of Citizenship and Culture.

n d Glen Meyer and Neutral Paleoethnobotany. Ph.D dissertation thesis in progress, Department of Anthropology, University of Toronto.

Smith, Huron H

- 1933 *Ethnobotany of the Forest Potawatomi Indians*. Bulletin of the Public Museum of Milwaukee 7:1-230.

Dear Editor:

Please find enclosed a cheque for my membership renewal. I have just received the May/June issue of *Arch Notes* and *Ontario Archaeology* and have thoroughly enjoyed both. In particular, I was extremely pleased with Dr von Gernet's editorial essay and look forward to future issues containing significant contributions to Ontario archaeology. My compliments to the chef, or editor in this case, for such a splendid essay and issue of *Ontario Archaeology*.

In the same vein, could you please pass on a sincere thanks to Nick Adams for his article "Gnawing Gently on the Metacarpals" and Colin Varley for "Meditations on Time, Mind and Manufacture: Excerpts from the Notes of William Russell". Both of these articles in *Arch Notes* were highlight 'reads' during the past year.

All is well in France. This summer I'm busy helping excavate a Roman/Visigoth

villa, reconstructing an 18th century stone windmill, plus organizing the first systematic survey of our commune (township) for this coming winter.

On a final note, I've met a young archaeologist (Gallo-Roman speciality) who would be interested in gaining an archaeological experience in Canada for a few months (minimum), plus the opportunity to improve her English. Although a salary is desired to offset expenses, she is willing to work for room and board. If any consulting firm, director of a research project or other organization is interested in providing a post to a skilled and enthusiastic worker, broadening their own French language skills and learning about another region of the archaeological world, they can write to me for her coordinates. She is available as of October 1994.

Best wishes for the next year.

Sincerely,

D Barry Gray

2 rue de l'Ecole Maternelle

34440 Nissan lez Enserune

France

Dear Mr Kirby,

I am writing to thank you for including archaeological 'licences issued' in *Arch Notes*. As a museum curator, I feel it is part of my rôle to ensure that the general public has an understanding about the importance of issuing archaeological licences for land and underwater work. Frequently we see individuals who feel they may conduct their own 'archaeological survey', and the current list of licence holders will be a good tool for advocating this issue. Thank you.

Sincerely,

Tracy Marsh

Director/Curator, Collingwood Museum

LETTERS TO THE OAS OFFICE

Dear Mr Garrad:

I am writing to thank you for the opportunity to participate as a volunteer on the Seed-Barker AkGv-1 site, for the June 1-5 period.

As a retired person (ex-geologist in the mining industry), I enjoyed very much the opportunity to learn something about an archeological dig and the associated laboratory work. The enthusiasm of Bob Burgar and his supervision was inspiring and I hope I shall be able to participate again in this, or some other of the Society's excavations.

Some years ago, I went as a volunteer to a dig in Jerusalem but found this one, just a short drive from home, just as interesting, with the added fillip of digging into our own heritage.

I am looking forward to the Open House at Kortright on June 26th.

Yours sincerely,

Alan Warburton

3454 Burning Oak Crescent

Mississauga, Ontario, L4Y 3L5

Dear Charlie:

This is a belated, but nonetheless sincere, note of appreciation for the extremely enjoyable and instructive week I spent at the Kortright Centre excavation from June 15 to 19.

The excavation site is fascinating, even to someone like me whose archaeological interests are far more oriented to Mycenaean, Archaic and Classical Greek civilizations.

The week was very well organized and run by Bob Burgar and his assistants, Glen, Tom and Sherry. There were all a delight to work with and learn from. Bob

and his crew were patient, instructive, easy to get along with and, in sum, a joy to work (if you can call it that) with.

I only wish I had the time to go back again for another week or more. Unfortunately, my business has become much more active (that's not all bad) thus depriving me of the free time I would like to have.

My thanks to all for a great week!

Sincerely,
Bob Miller

36 Fernwood Park Avenue
Toronto, Ontario, M4E 3G1

Dear Editor:

This past June I had the opportunity to participate in the OAS field school at the Seed-Barker site. It was a great opportunity to learn or brush-up on the proper techniques of excavating an archaeological site.

The site is Late Iroquoian. There were numerous longhouses situated on a ridge overlooking the Humber River. Unfortunately, a large portion of the site had been destroyed in the 1950s when it was dug up to get to gravel for use in highway building. The government allowed this to be done!!

Our mornings were spent in the field, shovelling the topsoil, trowelling to the subsoil, screening, mapping features and cross-sectioning features. The afternoons were spent in the lab sorting and cleaning the various artifacts that were found. Some afternoons we had lectures that helped explain the types of pottery, pipes and lithic points found and how they were made, and we learned about faunal archaeo-osteology.

We also had the opportunity to show visitors what we were doing in the field

and in the lab. The children were fun to watch, especially when their faces lit up because they saw an interesting object or even participated in cleaning some of the artifacts. Perhaps we helped to get some future archaeologists started!

I would like to thank the OAS for arranging this opportunity for us. Thank you to Bob Bugar for heading up this field school. I would also like to thank Bob's crew for all of their help: Thomas Carr, Glenn Kearsley and Sherri Hodgkins.

This was a great experience and I hope to be able to participate in something like this again. I'm sure there are others who would be interested, too.

Lynne Wheller

SCREENS FOR ARCHAEOLOGISTS

Well made sieving screens, any size and mesh, can be ordered from Wilf Weisensee, 41 Dundas Street, Dundas, Ont, L9H 1A1.
Telephone: (905) 628-6705

FREE PUBLIC LECTURE

THE THEATRE OF
PIETRABONDANTE and
THE SAMNITE CULTURE
(Pre-Roman)

Monday, October 31, 1994
at the Columbus Centre
901 Lawrence Ave. West
Toronto at 7.30pm.

ACCESS TO ARCHAEOLOGY: THE ONTARIO ARCHAEOLOGICAL SOCIETY'S EDUCATION RESOURCE KITS

By ELLEN BLAUBERGS

The Ontario Archaeological Society, Inc.
Paper Presented at the Canadian Archaeological Association
27th Annual Meeting
Edmonton, Alberta

May 7, 1994

Session 16: The Access to Archaeology Programme: Project
Examples

In 1991, the Ontario Archaeological Society received an Access to Archaeology Program grant in the amount of \$33,615.85 from the Federal Department of Communications to develop a series of education resource kits for schools. A most positive and productive alliance between the Region of Peel Museum and the OAS resulted in a series of kits which feature an overview of Aboriginal prehistory and contact with Europeans, as understood from archaeological investigation. The kits are distributed to schools and other groups by participating local Ontario museums in partnership with the OAS.

This paper will outline the various phases which led to the official launch of the "Discovering Ontario Archaeology" kit in 1992: design and assembly; promotion and administration; and distribution and maintenance. I will be referring to the actual "DOA" kit sitting here next to me, throughout this paper and hope that you have a chance to examine the reproduction artifacts, cultural booklets, teachers' directory, activity sheets and lesson plans after this session. By the way, the actual kit housing is a "Pelican Protector Equipment

Case", guaranteed to be indestructible. It is the Pelican Pro model, which retailed for \$148.00 in 1992. The Society purchased 11 of these and 11 of a smaller version at \$125.00. The smaller version will house a community speaker kit, a topic I will discuss later.

The grant money was intended to cover the first two of the project's three phases: Phase I: Design and Assembly, Phase II: Promotion and Administration.

Phase I - Design and Assembly.

This was probably the most lengthy and difficult stage. In fact, although a kit was officially launched in October 1992, a number of others were still in the assembly process.

The OAS Education Committee was mandated to complete the many different tasks covered under Phase I. Fortunately, the Committee was composed of a group of extremely dedicated and professional volunteers who logged thousands of hours during the many aspects of the process. The original committee of myself (at the time OAS Secretary and an archaeologist with the Toronto Board of Education's Archaeological Resource Centre), the OAS

President Christine Caroppo, and OAS Treasurer, Michael Kirby were soon joined by Josie Holden, Curatorial Assistant, In-House Education and Janice Calvert, Curatorial Assistant, Outreach Education, of the Region of Peel Museum. Two other competent committee members included Jeff Bursey, an archaeologist with the Ontario Ministry of Transportation, and Janie Ravenhurst, an elementary school teacher with an archaeological background.

As an aside, when the Thunder Bay chapter of the OAS learned that the Society was developing these kits, one of their first comment was, "for heavens sake, don't forget the North this time. Several years earlier, the Society had produced a magnificent poster entitled "Ontario's Archaeological Past". At that time additional panels which focused specifically on Northern Ontario's archaeological past were not included. With this in mind, the Education Committee immediately chose to include several kits with a Northern Ontario focus. In terms of the actual reproduction artifacts, this mandate was fairly easy to accommodate.

After an intensive hiring process in the spring of 1992, Haig Bedrossian, a graphic artist, was hired to produce original graphics, lay out the format of the cultural booklets to be included and assist in assembling the kits. Over the course of that summer and into the fall and winter, Haig worked incredibly long hours producing the Education Resource Kits and his contributions were most impressive.

The kits feature a series of booklets focusing on the major archaeological time periods of Ontario's past, well illustrated by original colour graphics. Separate booklets were written for northern and southern Ontario. The text for the book-

lets was derived from the regional prehistory submissions written by Hugh Daechsel, Andrew Hinshelwood, Carl Murphy and Jeff Bursey. The difficult task of working these sections into booklets for the target age groups was accomplished by Josie Holden, Janice Calvert, Christine Caroppo and myself. A section containing the methods of archaeology, a resource book and numerous activity sheets were also included. In each kit there are three reproduction projectile points made by avocational archaeologist, Fred Moerschfelder. Also, reproduction pots, net sinkers and bannerstones were made and provided by Dr. Dean Axelson, an exotic bird veterinarian and enthusiastic OAS member. Interestingly, Dr. Axelson's pots began to show evidence of spalling shortly after delivery. When he examined this unfortunate deterioration, it was revealed that he had been experimenting with an alternative temper which obviously was not working. A new set of pots was provided and these seem to be fine. Other artifact forms such as ceremonial axes, chevron trade beads, ceinture fleche and traders' sashes were purchased at Iroqcrafts. These were added, both to demonstrate the nature of different artifacts and for use in artifact-oriented activities. All artifacts are housed in ethafoam, a non-toxic, inert material recommended by artifact conservators.

A prototype kit was "field tested" by Helen Armstrong of the OAS's Ottawa Chapter and Janie Ravenhurst of Toronto. Both are teachers (high school and elementary) who have added archaeology to their courses of study over the years. Their comments were incorporated into the activity sheets, teacher's directory, lesson plans and a section entitled "What is Archaeology?".

Discovering Ontario Archaeology

Education Resource Kit

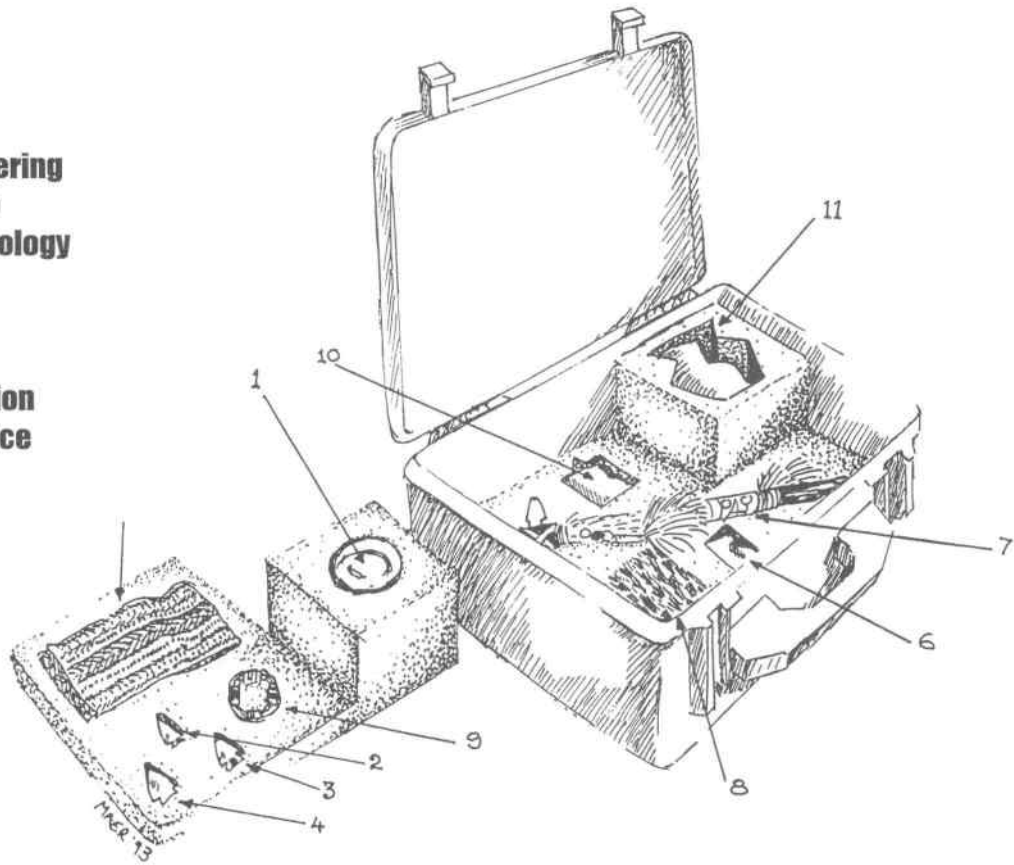

During this Design and Assembly phase, the Education Committee also decided to change the rather cumbersome name of the original project working title which was "Participation in Archaeology: Today and Tomorrow's Heritage (PATH), to "Discovering Ontario Archaeology" (DOA). It was felt that this new name was more appealing, dynamic, and that it was easier to recall the name behind the acronym, an important element in product recognition.

It was impossible to find a qualified translator to create a French-language version of the kit and remain within budget. We still hope to achieve this but are extremely doubtful. We may have been overly ambitious at the outset with this aspect of our goal. Our current thinking is to aim for separate project funding for French translation of the text once the English versions have enjoyed more circulation. In this way, any alterations based on the initial user response may be incorporated directly into the French version. Meanwhile, the OAS still has available its French-language educational poster on the archaeological history of the province.

Budget

While the committee was able to stay within budget, funds were reallocated since the initial proposal to the Department of Communications. The Committee found it impossible to find appropriate volunteers or co-op students willing to work over the summer to execute the art work and design phases of the project. After deliberation, we decided to reallocate funds from the co-ordinator and co-op student positions and hired an Ontario College of Art senior student to perform the art, design and kit assembly tasks.

Phase II - Promotion and Administration

Our original proposal calculated that a paid co-ordinator would manage the day-to-day function of kit loans. After investigating offers to enter into co-operative partnerships with educational and heritage institutions across Ontario to manage the day-to-day function of kit loans, the committee decided to by-pass the educational institution route completely. Previous experience had revealed that the incredible cumbersome bureaucracy within the Ontario Education Ministry was difficult to penetrate.

It was originally intended that one copy of the Society's "Ontario Archaeological Past" poster (produced several years ago), be shipped to each school in the province. The Education Ministry agreed to do this only if the Society produced a French language poster as well. This was fairly easy to accomplish because the Ministry provided inhouse services for the translation of the five written cultural panels. A bilingual archaeologist employed by the Toronto Board of Education provided additional translation services, gratis. When all was said and done, the poster received extremely limited and poor distribution and to date, most Ontario schools do not have a copy.

An alternative solution to the distribution problem was actually right under our noses. The Peel Museum was already interested in using a kit in their programming and it was decided that the kit could be distributed to schools and other groups by participating local museums. To date, four museums have entered into partnership with the OAS: the Region of Peel Museum, the St. Catherines Museum, the Peterborough Centennial Museum and Archives, and the Timmins Museum. Although several other museums have expressed interest in using the kits, con-

tracts remain unsigned. It is hoped that these institutions, who have felt the effects of declining school field trip budgets, will use the kit in their advertising to attract those "strapped for cash" schools to their facilities.

Phase III - Distribution and Maintenance

At present, the period of loan to museums includes a provisional first-year contract period from January 10, 1994 to June 30, 1994. During this 24 week period the kit should be circulated to approximately ten schools (or other groups), each for two-weeks. The OAS recommends that a charge of \$30.00 per school (or \$3.00 per school day) be made by the Museum, plus any distribution costs. The museum is responsible for promoting and circulating the kits. Museums are encouraged to circulate it as much as appears necessary and reduce or increase the recommended fee per school as they see fit.

The museums' net income should well exceed their costs. During 1994 (the provisional 'start-up' period), the OAS is charging museums 50% only, of the recommended \$30.00 per school. Even if they achieve many more than the expected 10 'turnarounds', their total cost will not exceed \$150.00

An evaluation form in the kit will help the Society maintain statistics re lengths of loan, fees charged, numbers of users, etc.

All museums are requested to arrange for the return of the kit, along with evaluation sheets, to the OAS office by the last week of June 1994. Eventually, with sufficient funds being generated, the Society can replace or repair broken artifacts, loose or missing booklet pages, etc.

During our initial research into producing these kits, a visit to the Royal Ontario Museum's Education and Outreach De-

partment, revealed that this institution has its own kits (covering all kinds of topics) which go directly to schools all over the province. It was strongly suggested by the ROM staff, that any kits we produce had to look top-notch and professional. The ROM, over the past 20 years has had to replace relatively few artifacts in their myriad of kits. They feel that this positive relationship between kits and users is because most students and teachers will handle something with much more care if the items are part of a slick-looking package. We will see as the kits are returned if the ROM's experience holds true for the OAS as well.

The OAS has started to promote the Education Resource Kit and the names of participating museums in all of its appropriate publications and meetings. It will circulate specific information on the kit, and the names of contact people at the participating museums, to school boards in Ontario. Support for the Museums is always available from the main OAS office in North York. Minor changes in the kits may be made in the 'off-season' based upon evaluations received from the teachers and the museums.

The value of the DOA kit and contents, for insurance purposes, is \$1,250.00. Replacement costs for individual items are as follows: Case and lock - \$350.00 Artifacts - total - \$450.00 Booklets, Activity Sheets, Binders - \$450.00

A Second Kit-type

A second type of kit entitled "community speaker kits" was in simultaneous production with the Education Resource versions. Although not yet completed, the community speaker kits will be aimed primarily at an adult audience but could be adapted for children. They contain a carousel with a standard set of slides, such

as distribution maps of sites by period across Ontario, speakers notes on presentation, and an overview of the archaeological history of the province. It is intended that the OAS speakers will provide artifacts and additional slides appropriate to the region in which the talk is being given. It is also intended that these speakers will work closely with the Society's proposed network of archaeological volunteer stewards. We hope that these kits will be available in 1995.

In general, the DOA kit project has received very enthusiastic reviews. As with so many projects, the original amount of time projected as being necessary to complete this project was vastly underestimated. All of the OAS volunteers and employees involved in this project were asked to keep a log of personal time spent on any aspect of the kits. Several crucial volunteers are "burned-out" and would like to pass their aspects of the project onto someone with more energy. Once the Community Speaker kits are completed and in circulation, I envision at least one part-time employee administering so many crucial elements related to all of the kits including delivery, return, enquiries, updating, additional kit production, finance etc.

I would be pleased to answer any questions about the kit after this session or sometime today. Before closing, I would like to express the Ontario Archaeological Society's sincere appreciation to the Access to Archaeology Program for providing the funding to foster more enhanced awareness and appreciation for Ontario's past through archaeology.

Acknowledgements

Thank you Jeff, Janice, Christine, Josie and Michael. The information in your various reports over the past few years

added much to the accuracy and detail of this presentation.

The Toronto Society of the
ARCHAEOLOGICAL INSTITUTE OF
AMERICA
announces its
MONTHLY LECTURE SERIES FOR
1994-1995

1994

October 26

Balloon Archaeology: Ancient Crete from the Air

J Wilson Myers, American School of Classical Studies at Athens

November 16

Archaeology in Nepal: An Emerging Discipline

Nancy Wilkie, Carleton College
1995

January 25

Augusta Emerita (Mérida, Spain): From Roman Colony to Provincial Capital
Jonathan Edmondson, York University

March 1

The Greeks and the Body Beautiful: The Construct of Self in Art and on the Stage
Richard Green, University of Sydney
To be followed by our annual Members' Banquet

March 29

The Sanctuary of Demeter and Kore/Persephone in Cyrene, Libya
Susan Kane, Oberlin College

All lectures to be held in the lecture room of the McLaughlin Planetarium, Royal Ontario Museum, 100 Queen's Park, with the exception of the March 29 lecture in University College. Lectures start 5:15 pm and admission is free. Non-members are most welcome. Further information: (416) 978-3290, 247-0886 or 489-0209.

Ontario Archaeological Society Inc.

21st ANNUAL SYMPOSIUM

"ORIGINS OF THE PEOPLE OF THE LONGHOUSE"

OCTOBER 21 - 23, 1994

All events take place at the Primrose Hotel, Toronto
111 Carlton Street at Jarvis

Symposium Ticket

\$30 by pre-registration

\$35 at the door

Students: \$15 by pre-registration only

(Proof of status required to pick up ticket)

Friday Evening: Social Gathering at 8 p.m., with finger food, cash bar - and who knows what...

The Presidents' Meeting also takes place on this evening.

Saturday, and Sunday Morning: Registration desk opens 8:15 a.m. Papers, displays, sales, door prizes - and at 4:00 p.m. the **Annual Business Meeting**, including the last opportunity for nominations to the 1995 Board of Directors.

* * * * *

Saturday Evening: Banquet at 7:30 p.m. (cash bar opens at 6:00), and presentation of awards. To be followed by a presentation by Chief Jacob Thomas from the Six Nations Reserve in Brampton. **Tickets \$35.00 each by pre-registration only.** Cash bar open to all.

* * * * *

To pre-register, call the OAS Office at (416)730-0797. VISA accepted.

COORDINAMENTO DEI MOLISANI NEL MONDO, ONTARIO

ISTITUTO ITALIANO
DI CULTURA

THE ONTARIO ARCHAEOLOGICAL
SOCIETY INC.

PRESENT
A FREE PUBLIC LECTURE

ISERNIA - LA PINETA

is a 730,000 year old human habitation site in Central Italy, occupied by Homo Erectus. It has the highest concentration yet found of fossil remains (rhinoceros, elephant, lion, giant elk, etc.), all found in conjunction with a large number of stone tools scattered through the old living floors.

Come and find out what this important site tells us about our distant ancestors.

Royal Ontario Museum Theatre
100 Queen's Park, Toronto
Wednesday, November 2, 1994
at 8 p.m.

Refreshments 7.30p.m.

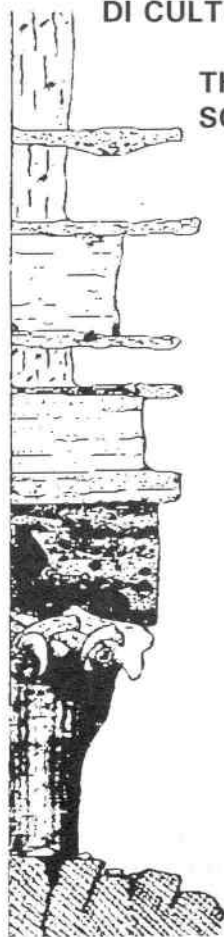



FROM THE O.A.S. OFFICE

CHARLES GARRAD

NOTICE FROM NOMINATING COMMITTEE

A Nominating Committee of three members is appointed to prepare a slate of seven or more candidates for office as Directors of The Ontario Society during the business year 1995. Bob Bugar is chair of the Committee and now solicits nominations of consenting candidates from members.

Written nominations with evidence of the candidate's consent may be forwarded to the Nominating Committee in confidence care of the OAS Office, the envelope being marked "Attention - Nominating Committee". Bob can be reached at home at 905-856-0270. The Nominating Committee will present its slate and report to the Board of Directors and general membership at the Annual Business Meeting in October, at which time nominations may be made from the floor before closure. An election, if necessary, will be held by mailed ballot accompanying the November-December 1994 issue of *ARCH NOTES*.

This notice is intended to comply with Article VI of the Society's Constitution.

PASSPORT TO THE PAST PROGRAM UPDATE

Only five Volunteer Opportunity Bulletins have been mailed this year to date compared with ten last year. But our "Access to Archaeology" series of four back-to-back field schools on the seed-

Barker Site under Bob Bugar was a huge success, with all schools filled. Some funding in support of this major event has been received from the Ontario Heritage Foundation. The federal Access to Archaeology Program also sent funds to advertise the wrap-up Heritage Day at the Kortright Centre, but after the event. If you are not receiving Volunteer Opportunity Bulletins but believe you should be, please contact the office.

1994 OVERSEAS TRIP UPDATE

Forty OAS members and guests departed to Greece and Turkey on September 9. The OAS owes a debt of gratitude to its travel agent for exceptional care and concern for us, and recommends to anyone arranging for single or group travel to contact Nick Smith, Upper Canada Study Holiday Limited, 80 St. Clair Avenue East #2209, Toronto, Ontario M4T 1N6, tel:(416)920-0159 fax:(416)920-1674. Thank you, Nick Smith and Christiane Löck.

AVAILABLE - CHAMPLAIN SOCIETY MEMBERSHIP

The object of The Champlain Society is the publication of works pertaining to Canada. Members receive volumes as they are published and also may purchase back issues. Individual Membership costs \$40 annually + GST. Right now there are available some really exceptional back publications. For details enquire by telephone at (416)693-2693.

WHERE DOES YOUR MONEY GO?

CHARLES GARRAD

As the letter which goes to every new member states, OAS membership fees are kept very low by the financial support of both levels of government and the donated efforts of volunteer members. In addition we create interest income from endowments, make sales, solicit donations, undertake revenue-producing activities (e.g. trips), and receive other contributions. How effective the Society is at this is revealed in the 1993 Financial Statements to be presented at the ABM and part included in this issue of *ARCH NOTES*.

[1] the total income from membership dues in 1993 was less than \$20,000, grants obtained from government agencies exceeded \$70,000.

[2] with a total membership of 737 and a total expenditure of \$108,892, the Society spent \$147.75 for every member.

[3] individual and family members contributed 14% of the Society's income. An individual member who paid \$28 received \$147.75 in benefits, a ratio of more than 5:1.

[4] fees have not gone up since 1991 but since that time some costs have risen dramatically. Postal rates for example have not only gone up but the special favourable Printed Rate and Second Class were abolished.

[5] the direct cost of *ONTARIO ARCHAEOLOGY* in 1993 was matched within \$50 by SSHRCC funding, with the result that the two 1993 issues cost members only 3½¢ each. Nevertheless an Endowment Fund was begun to create interest income for the future. In 1994 the size of *ONTARIO ARCHAEOLOGY* was increased by 60%.

[6] The expenses of the OAS Office are tightly controlled. The largest item, the salary paid to our one employee, was mainly covered by the Ministry support grant. The remaining costs, rent, photocopier, fax machine, telephone and so on, are essential to allow the volunteer Board and other officers to perform their tasks, which range from producing *ARCH NOTES* to representing archaeology to the government, and procuring those grants which have so far enabled the fees to remain so low. Without this activity the Individual 1993 fee would have been not \$28 but \$148. Some projects, such as Passport-to-the-Past, are almost entirely subsidized by the OAS, the cost of operation being far in excess of the dues paid by members.

[7] About 34% of Society members also belong to Chapters to enjoy additional local benefits. A support grant is available to every Chapter from the Society. In 1993 this resulted in one Chapter receiving more from the Society than from its own members. In addition the Society contributes towards Chapter costs of being represented at the annual Chapter Presidents' Meeting.

[8] In summary the 1993 Board can take satisfaction in that the Individual member who paid \$28 to the OAS received in return more than five-and-a-half times this amount in services. Should the funding agencies at some future time view the members' contribution as disproportionately low, then an increase in the fee, or an adjustment of what services are included in the fee, will be necessary. Until then it is hoped the present level of outside funding can be sustained.

The Ontario Archaeological Society Inc.

126 Willowdale Ave., North York, Ontario M2N 4Y2

BALANCE SHEET

December 31, 1993

ASSETS

	1992	
Cash in Banks	\$4,416.27	\$7,430.63
Term Deposits, GIC's	\$168,387.37	\$169,350.85
Total Current Assets	\$172,803.64	\$176,781.48
Equipment	\$20,711.36	\$21,396.11
Accumulated Depreciation	\$13,651.09	\$10,466.99
Total Fixed Assets	\$7,060.27	\$10,929.12
TOTAL ASSETS	\$179,863.91	\$187,710.60

Approved by the Board of Directors

PRESIDENT *Norma E. Kuwerton*

TREASURER: *M. Kennedy*

AUDITOR:

I have examined the above Balance Sheet and the attached statement of receipts and expenditures together with the accounting records of The Ontario Archaeological Society Inc. In common with similar organizations, donations and other funds received from the public cannot be properly verified because of their nature, and my verification of revenue from these sources was limited to a comparison of membership and donation records with bank deposits. Subject to this observation, in my opinion these accounts present fairly, in all material respects, the financial condition of the Society at December 31, 1993 and the receipts and expenditures for the year ended December 31, 1993.

[Signature]

Date: March 31, 1994

LIABILITIES

	1992	
Provision for:		
O.A. Endow. Fund	\$90,000.00	\$82,997.95
Field Manual	\$3,245.40	\$0.00
Educ. Kits	\$15,535.07	\$21,471.45
Total Liabilities	\$108,780.47	\$104,469.40
EQUITY		
Awards Fund	\$3,000.00	\$3,000.00
OAS "Future" Fund	\$30,000.00	\$27,000.00
Retained Earnings	\$38,083.35	\$53,241.20
Total Equity	\$71,083.35	\$83,241.20
LIABILITIES AND EQUITY	\$179,863.82	\$187,710.60

The Ontario Archaeological Society Inc.

126 Willowdale Ave., North York, Ontario M2N 4Y2

STATEMENT OF RECEIPTS & EXPENDITURES for the year ended December 31, 1993

RECEIPTS			EXPENDITURES		
		<i>1992</i>			<i>1992</i>
Membership Dues		\$19,792.64	Publications	\$25,778.92	\$24,667.42
Government Grants	\$72,803.00		Symposia	\$268.20	\$115.30
less to be spent in 1994	<u>\$3,245.40</u>	\$69,557.60	Passport Program	\$837.24	\$2,000.00
Donations		\$1,793.00	Educational Kits	\$5,936.38	\$11,528.55
Interest & U.S. Exchange		\$8,632.54	Chapter Support	\$200.00	\$1,069.46
Publications		\$1,373.85	Awards	\$202.67	\$167.95
Passport-T-T-Past Programme		\$480.00	Executive Travel	\$1,816.16	\$1,411.93
Tours, lectures etc.		\$664.03	Admin./Rent/Utilities	\$46,385.59	\$53,517.46
GST Rebate		\$1,666.62	Supplies/Phone/Insurance	\$6,356.11	\$6,206.59
			Strategic Planning	\$446.10	\$4,332.43
			Depreciation	\$4,277.92	\$5,419.75
			Outreach	\$16,899.10	\$1,048.60
			Tours, lectures etc.		\$251.71
			A.S.P. Manual	\$5,424.60	
Total		\$103,960.28	Total	\$114,829.19	\$111,737.15
			Less Gov't. Grants		
			carried forward	\$5,936.38	\$13,528.55
TOTAL RECEIPTS		<u>\$103,960.28</u>	TOTAL EXPENDITURES	<u>\$108,892.81</u>	<u>\$98,208.60</u>
(DEFICIT)/EXCESS OF RECEIPTS OVER EXPENDITURES:			(\$4,932.53)	1992	<u>\$59,292.10</u>

Editorial

It is not often that Arch Notes gives you an editorial. Perhaps twice in the last twenty years. However, there are occasions when one would appear to be due. In September, 1974 I agreed to take over as editor of Arch Notes, at the request of our then president, Charles Garrad, and for the last ten years of that twenty I have been desperately trying to find someone to hand it over to. Not that I haven't enjoyed being editor, for which I thank the Society, but in the belief that one can be too long in any one job. I think one tends to get into a routine and lose, perhaps, some of the original enthusiasm and creativity. I hope I haven't but I suspect I have.

At last, we have found somebody to take over as editor of Arch Notes - not perhaps for twenty years, but at least for three and maybe more. Editorship of Arch Notes is an appointed position, not an elected one, and is entirely voluntary. For the last twenty years, at least, the editor has sat in on every executive/board meeting of the O.A.S. (albeit for the last eight as a director as well) and this certainly gives one an understanding of what the OAS is about and what it is doing. I hope this will continue. The Arch Notes Committee (usually just the Editor!) will I hope coopt me to its membership, for the period of transition, anyway.

As I start, and finish, my 21st year as Editor with this issue I should like to thank those who have helped me and Arch Notes to achieve what we have:

The OAS presidents since 1974 (eleven, I believe), the Executive Committee/ Board

of Directors and the Administrator/ Executive Director of the OAS; Janet Illingworth Cooper - our main reporter in my early days, my favourite typist (and this before we began paying for typing) and occasional designer for the subtle changes that have sporadically appeared on our front page; Sharon Hick for help in the 1970s when we still used our gestetner-like machine and had to collate our pages by hand; Jock McAndrews for suggesting our 'half-size' format back in 1977; Annie Gould of the Toronto Chapter (before it became a Chapter) for the numerous reports of all the meetings; Heidi Lenzner for lots of free typing; our main typist of recent years, Liliias Brown-Little, displaced by technology and its diskettes; and of course all our contributors without whom we should not be. And last, but not least, my wife Christine, who, before I foisted this lot onto the new OAS office in 1988, helped me with the labelling, stamping, stuffing, sealing and mailing of Arch Notes as well as with many other things.

And who is the new editor? Come to the annual business meeting at the symposium and I'll introduce you there. Suffice to say for now that the editor-to-be is a Ph.D student in archaeology, has the necessary computer-literacy and equipment to produce Arch Notes "camera-ready" for the printer, understands that regularity of issue is the abiding principle of newsletter success, and has been a member of the OAS for 4/5 years. See you there.

Once again, I thank the OAS for allowing me to be the editor of Arch Notes.

Michael W. Kirby

O.A.S. CHAPTERS

GRAND RIVER/WATERLOO

Vice-President: Ken Oldridge

Secretary: Lois McCulloch, 23 Caledonia St.; Guelph, Ontario, N1G 2C4

Newsletter: THE BIRDSTONE - Editor: John D. A. MacDonald

Fees: Individual \$7 Meetings: Usually at 8.00 pm on the 3rd Wednesday of the month, except June - August, at the Adult Recreation Centre, 185 King Street W., Waterloo or the John F. Ross Collegiate.

President: Marcia Redmond (519) 894-5807

Treasurer: Jack Redmond

HAMILTON

Treasurer/Secy.: Jacqueline Fisher, Box 57165, Jackson Station, Hamilton, Ontario L8P 4X1

Newsletter: Editor: John Triggs

Fees: Individual \$10. Meetings: Usually at 8.00pm on the 2nd Wednesday of the month, except June - August, at Dundurn Castle, Hamilton.

President: Joseph Muller (905) 525-1240

LONDON

Vice-President: Chris Ellis

Secretary: Lorelyn Giese, Grosvenor Lodge, 1017 Western Rd., London, N6G 1G5

Newsletter: KEWA - Editor: Neal Ferris

Fees: Individual \$15 Meetings: Usually at 8.00 pm on the 2nd Thursday of the month, except June - August, at Grosvenor Lodge, 1017 Western Rd.

President: Pat Weatherhead (519) 438-4817

Treasurer: Harri Mattila

Western Rd., London, N6G 1G5

Fax (519) 645-0981

OTTAWA

Vice-President:

Secretary: Lois King, Box 4939 Station E, Ottawa, ON K1S 5J1

Newsletter: THE OTTAWA ARCHAEOLOGIST - Editor: Rachel Perkins

Fees: Individual \$15 Meetings: Usually at 7.30 pm on the 2nd Wednesday of the month, except June - August, at the Victoria Memorial Building, Metcalfe & McLeod Streets, Ottawa.

President: Jim Montgomery (613) 730-2377

Treasurer: Jack Earnshaw

THUNDER BAY

Vice-President: Scott Hamilton

Newsletter: WANIKAN - Editor: A. Hinshelwood

Fees: Individual \$5 Meetings: Usually at 8.00pm on the last Wednesday of the month, except June - August, in the Board Room, M.C.T.R., 1825 East Arthur Street, Thunder Bay.

President: Frances Duke (807) 683-5375

Secretary/Treasurer: Andrew Hinshelwood

331 Hallam St., Thunder Bay, Ontario, P7A 1L9

TORONTO

Vice-President: Wayne McDonald

Secretary: Annie Gould, Box 241, Station "P", Toronto, Ontario, M5S 2S8

Newsletter: PROFILE - Editor: Valerie Sønstenes

Fees: Individual \$10 Meetings: Usually at 8.00pm on the 3rd Wednesday of the month, except June - August, at Room 561A, Sidney Smith Hall, St. George Street, Toronto.

President: Greg Purmal (905) 880-4481

Treasurer: Eva MacDonald

WINDSOR

Vice-President:

Secretary: Sandra Lesperance, 3461 Peter St. #507, Windsor, On. N9C 3Z6

Newsletter: SQUIRREL COUNTY GAZETTE - Editor: Peter Reid

Fees: Individual \$12 Meetings: Usually at 7.30pm on the 2nd Tuesday of the month, except June - August, at the Third World Resource Centre, 125 Tecumseh W., Windsor

President: Suzanne Gero (313) 393-9309

Treasurer: Ilinka Temerinski

The Ontario Archaeological Society Inc.

126 Willowdale Ave., North York, Ontario M2N 4Y2

Phone, Fax or Modem - (416) 730-0797

BOARD OF DIRECTORS 1994

Treasurer/Secretary

Mr. Henry H. van Lieshout
81 Overbank Crescent
Don Mills, Ontario
M3A 1W1
(416) 446-7673

PRESIDENT

Ms Norma E. Knowlton
418 Bouchier St.
P.O. Box 13
Roches Point, Ontario
L0E 1P0
(905) 476-4747

Director of Publications

Mr. Michael W. Kirby
P.O. Box 579
Markdale, Ontario
N0C 1H0
(519) 986-4026

Director of Professional Services

Ms Lise A. Ferguson
32 Bonnyview Drive
Etobicoke, Ontario
M8Y 3G6

Director of Public Services

Mr. Tony Stapells
39 McKenzie Ave.
Toronto, Ontario
M4W 1K1
(416) 962-1136

Director of Chapter Services

Mr. Stewart R. Leslie
187 Delmar Drive
Hamilton, Ontario
L9C 1J8
(905) 389-2394

Director of Member Services

Ms Anne La Fontaine
100 Quebec Ave. #1502
Toronto, Ontario
M6P 4B8

EXECUTIVE DIRECTOR

Mr. Charles Garrad
103 Anndale Drive
North York, Ontario
M2N 2X3
(416) 223-2752

PUBLICATIONS

Scientific Journal: ONTARIO ARCHAEOLOGY
Newsletter: ARCH NOTES
Special Publications: (As advertised)

FEES

Individual: \$28
Family: \$34
Institutional: \$55
Life: \$400